

Mercury BASE
watsonconsoles

DISPATCH USER WIRE-UP GUIDE

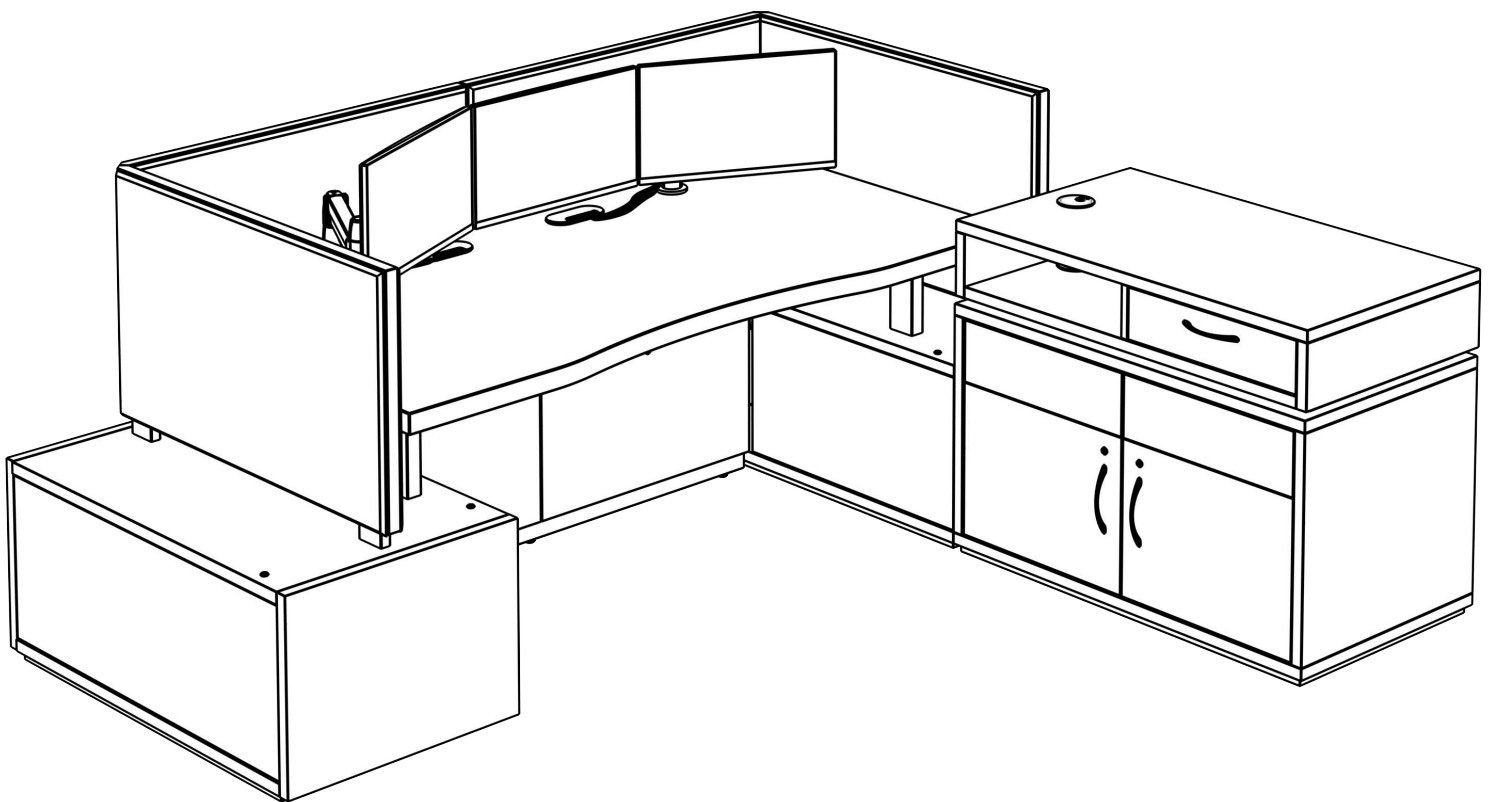

PRODUCT TYPICAL

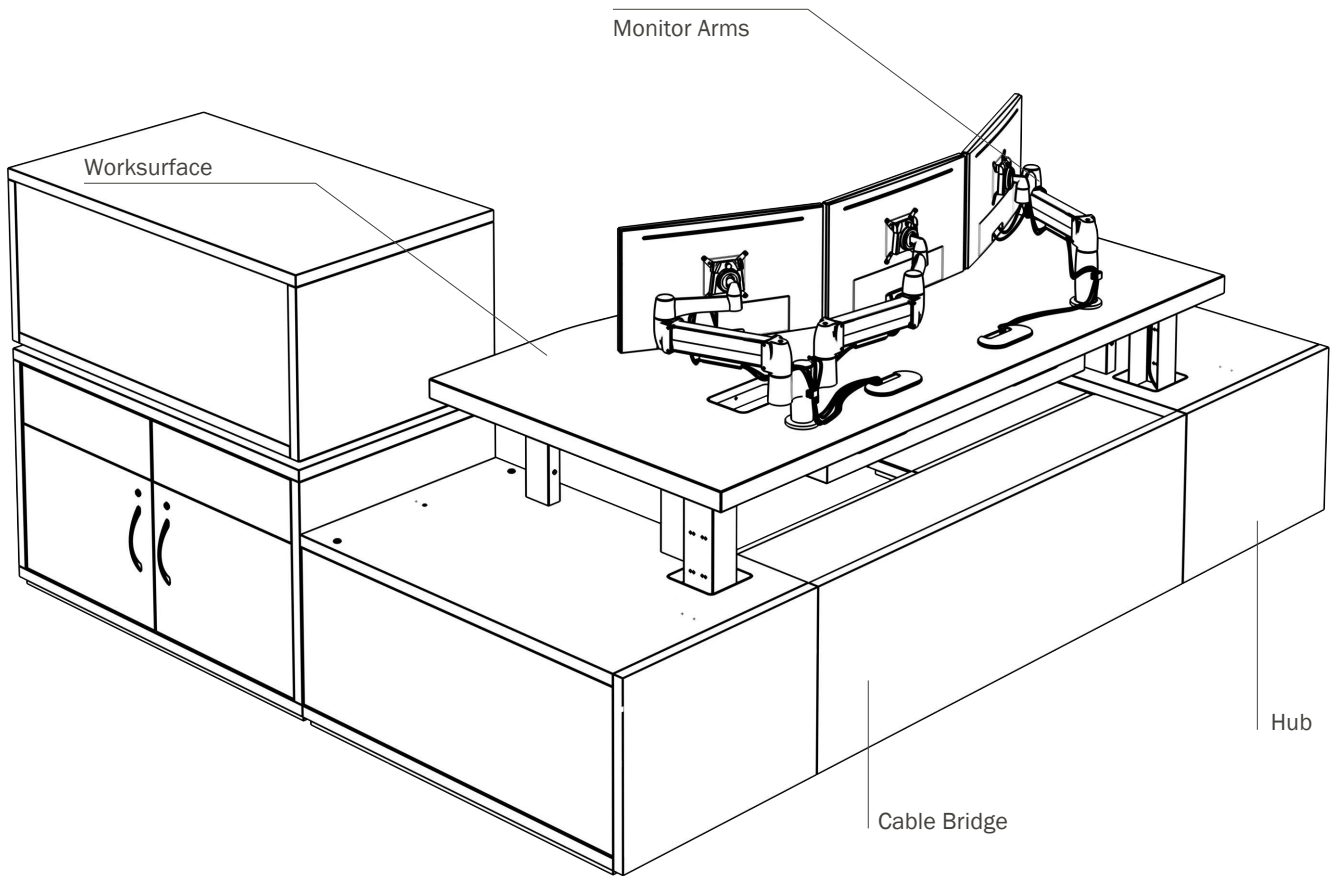

- 1. Monitor Power Cables**
With the monitor arms fully extended to the highest position, run all monitor power cables down the nearest grommet hole. Plug the power cords into the power strip in the J-channel.

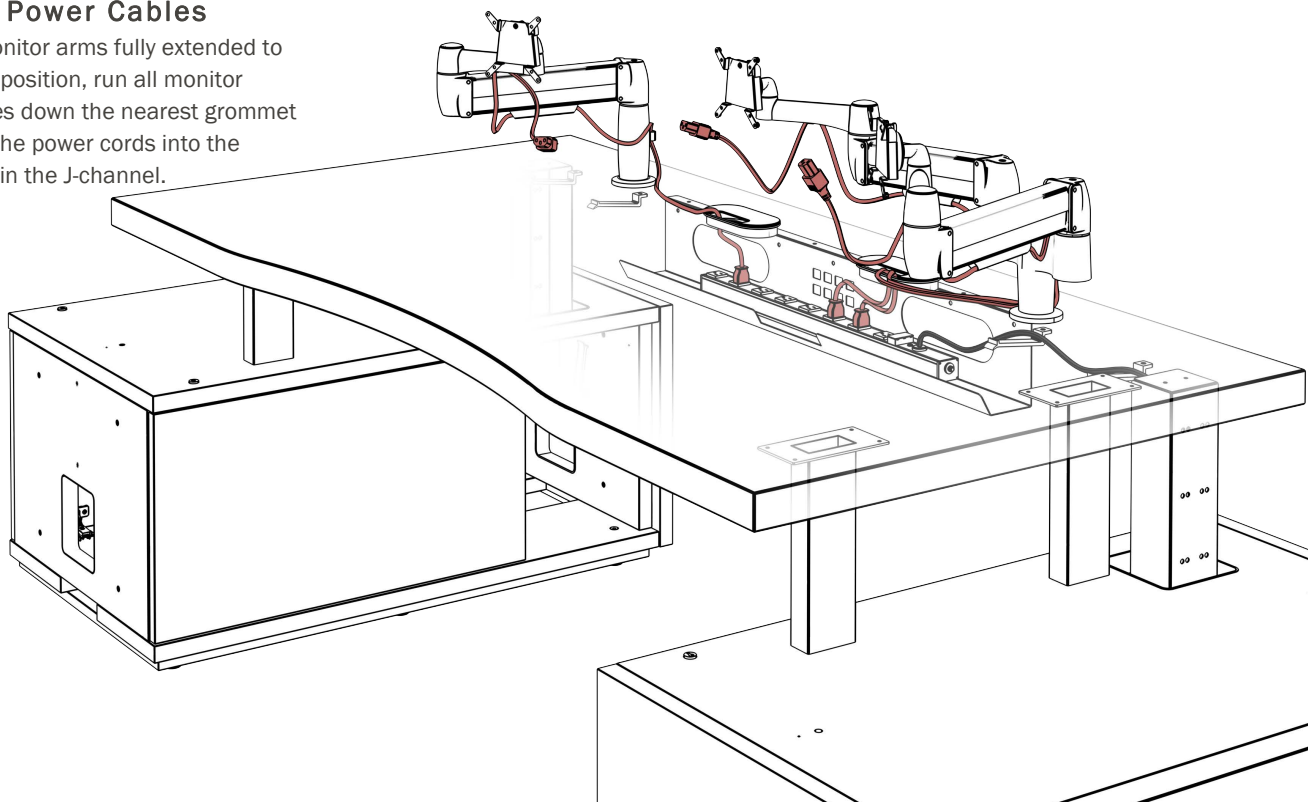

2. Monitor Display Cables

Run all monitor display cables down the nearest grommet hole. Use the cable clips shown below to route the cables along the underside of the worksurface and into the wire management shroud located below the worksurface

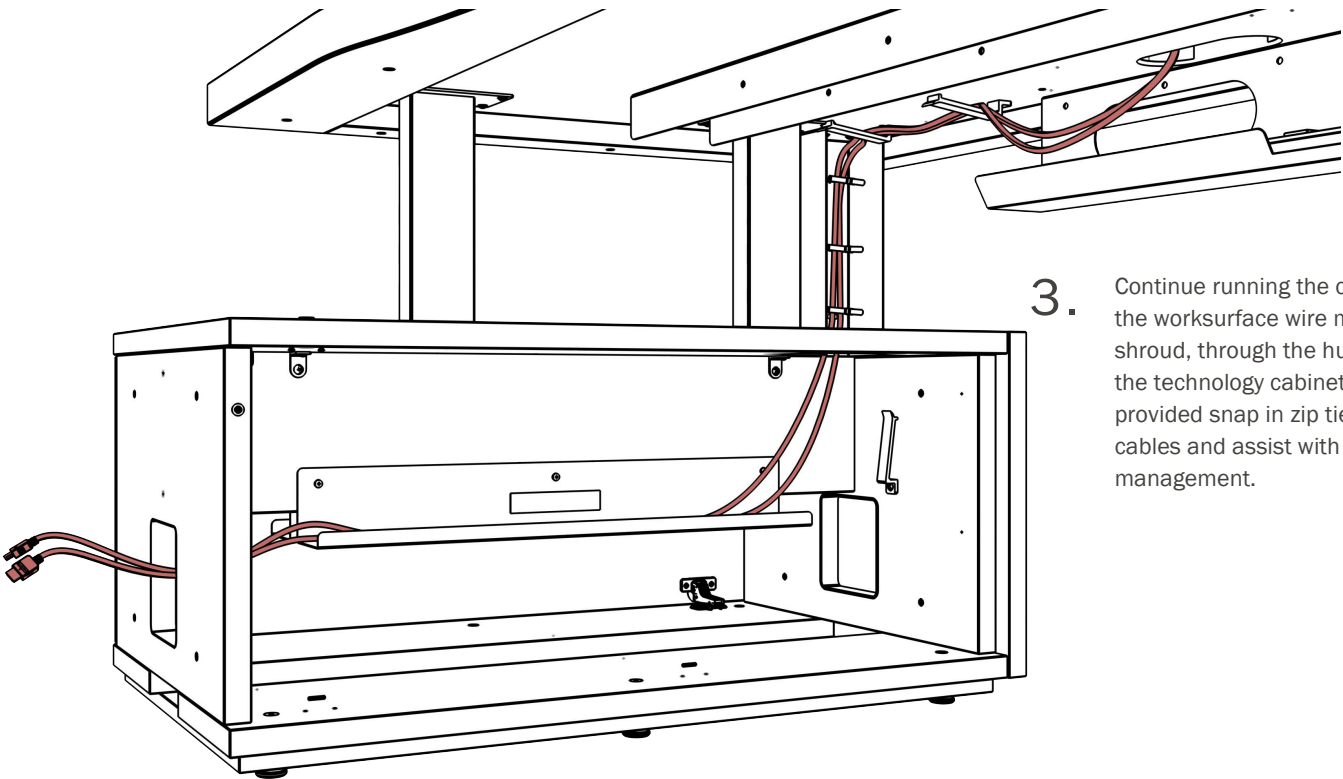
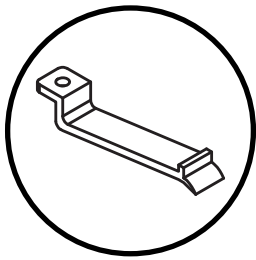
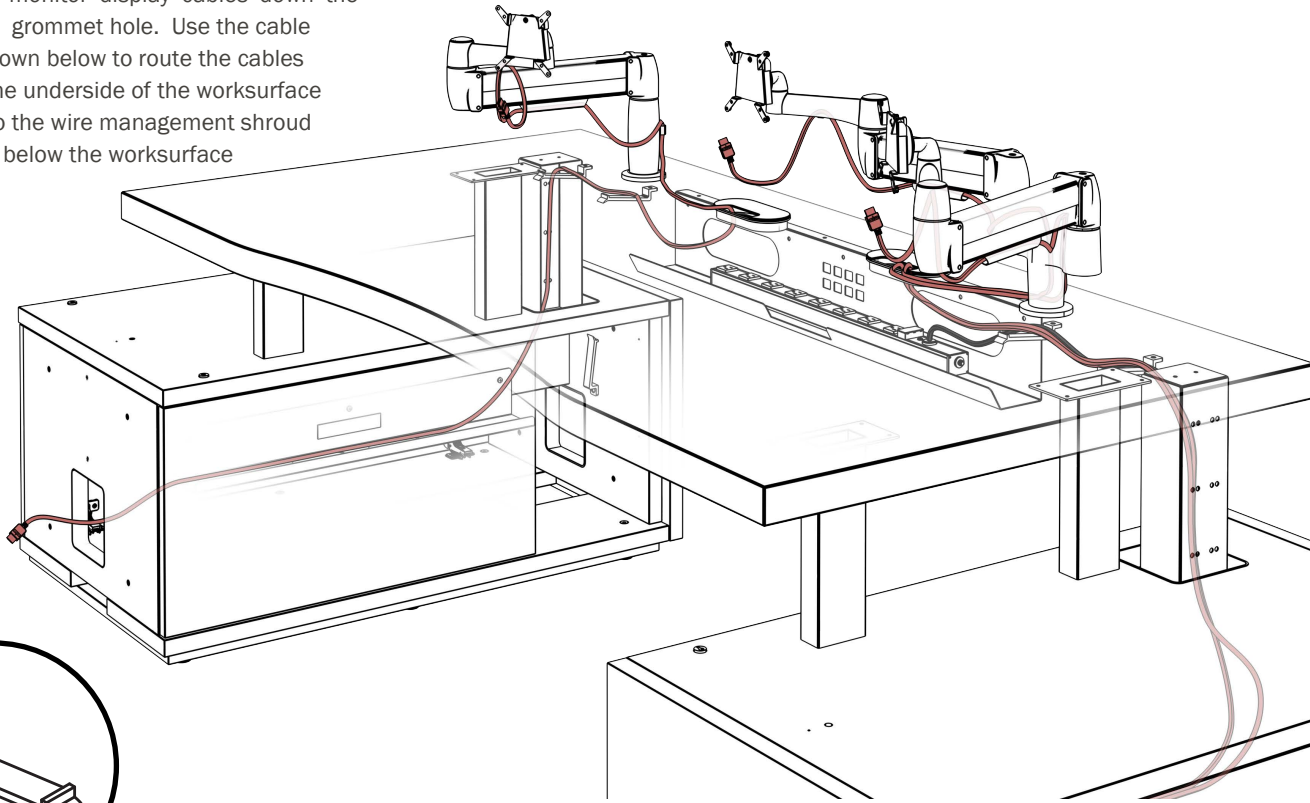

3. Continue running the cables down the worksurface wire management shroud, through the hub, and into the technology cabinets. Utilize provided snap in zip ties to bundle cables and assist with cable management.

4. Tech Link Option

Plug the user data cables into their respective ports on the Tech Link bracket mounted underneath the worksurface. Route all user data cables along the underside of the worksurface using provided cable clips and down through the rear wire management shroud.. Route the cables horizontally through the hub in the same manner as the video cables.

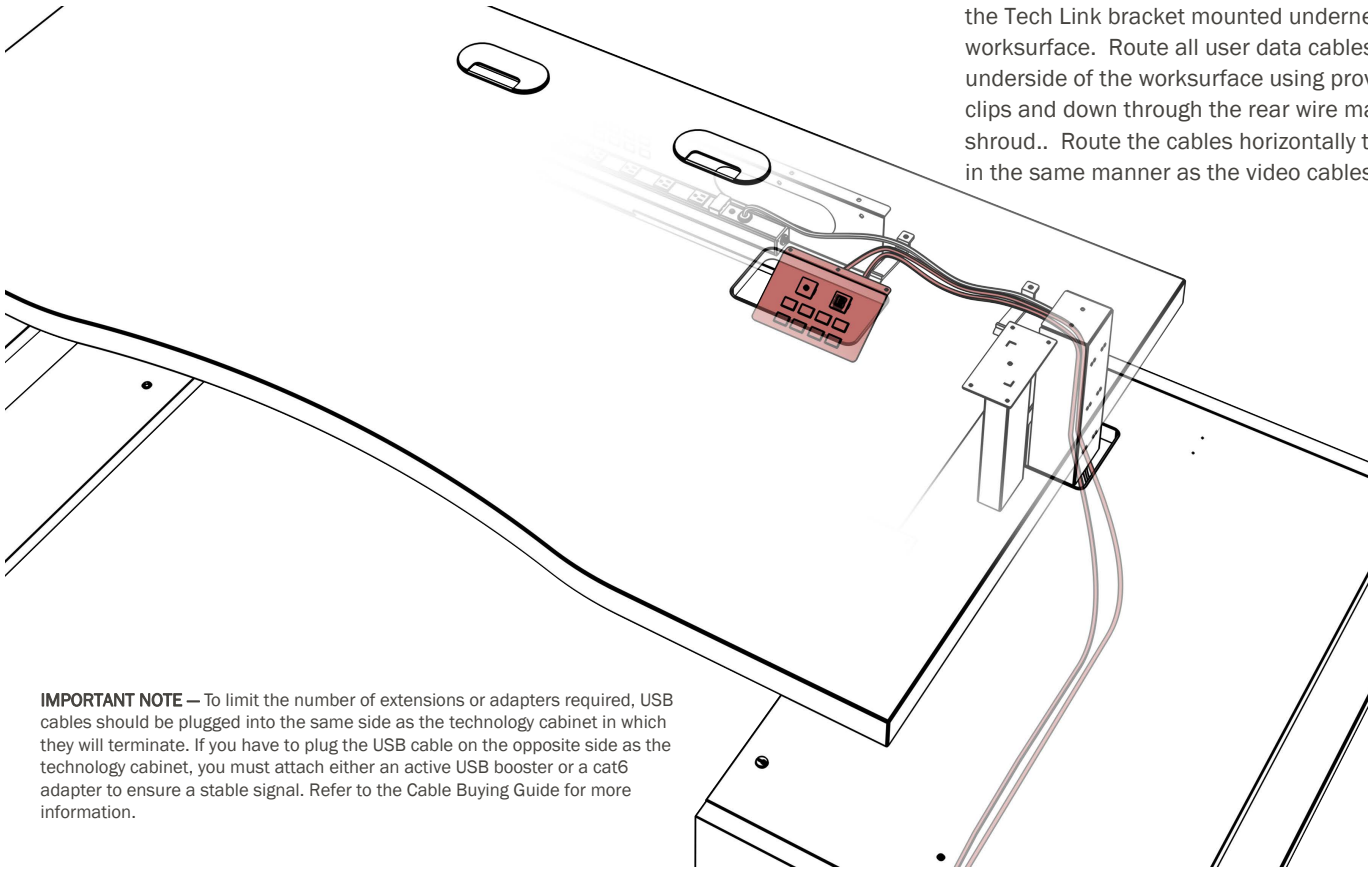

IMPORTANT NOTE — To limit the number of extensions or adapters required, USB cables should be plugged into the same side as the technology cabinet in which they will terminate. If you have to plug the USB cable on the opposite side as the technology cabinet, you must attach either an active USB booster or a cat6 adapter to ensure a stable signal. Refer to the Cable Buying Guide for more information.

5. Pop-Up 110V Convenience Power (Optional)

Route the convenience power outlet cord underneath the worksurface using provided cable clips and down the energy chain . Plug into facility power.

